

**SECTION
CONCRETE DRIVEWAY**

NOTES:
1. SAW JOINTS 2" DEEP @ 10' MAX SPACING WITHIN 12 HRS OF PLACEMENT. FILL JOINT WITH SEALANT

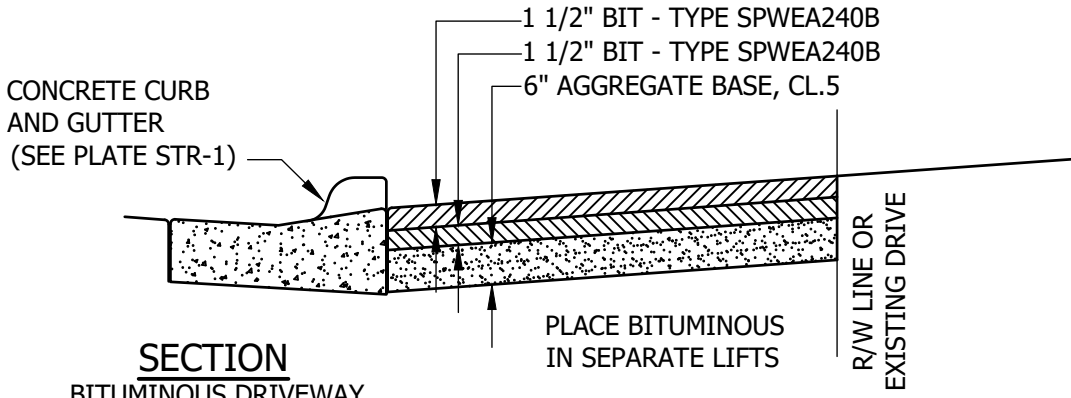

**SECTION
BITUMINOUS DRIVEWAY**

PLACE BITUMINOUS IN SEPARATE LIFTS

MATCH CONC. DRIVEWAY PAVEMENT TO BACK OF CONC. CURB & GUTTER

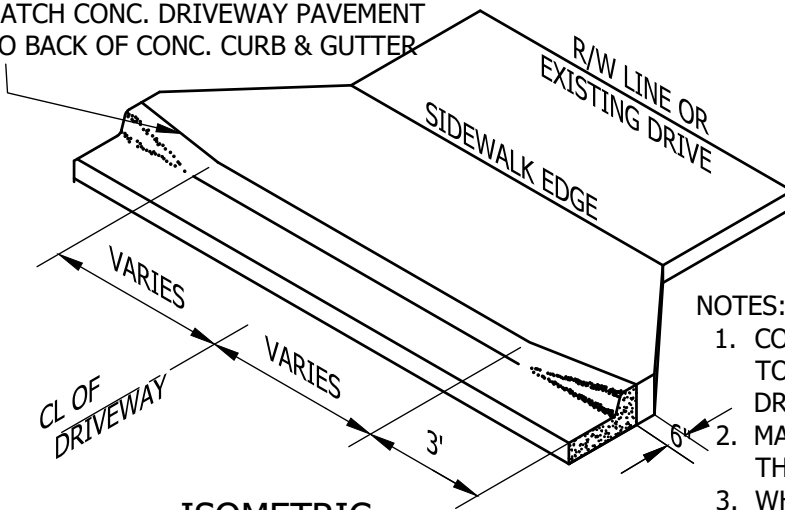

ISOMETRIC

NOTES:
1. CONTROL JOINTS IN CONCRETE CURB NOT TO EXCEED 10' SPACING THROUGH DRIVEWAY SECTION.
2. MATCH EX. DRIVEWAY SECTION IF GREATER THAN SHOWN.
3. WHERE SIDEWALK IS NOT PRESENT, DRIVEWAY APRON SHALL BE A MINIMUM OF 5' FROM BACK OF CURB. VARIATIONS TO BE DETERMINED IN THE FIELD BY ENGINEER.



**RESIDENTIAL DRIVEWAY
OR ALLEY SECTION
(B618 CURB)**

LAST REVISION:
JAN 2022

PLATE NO.
STR-3